

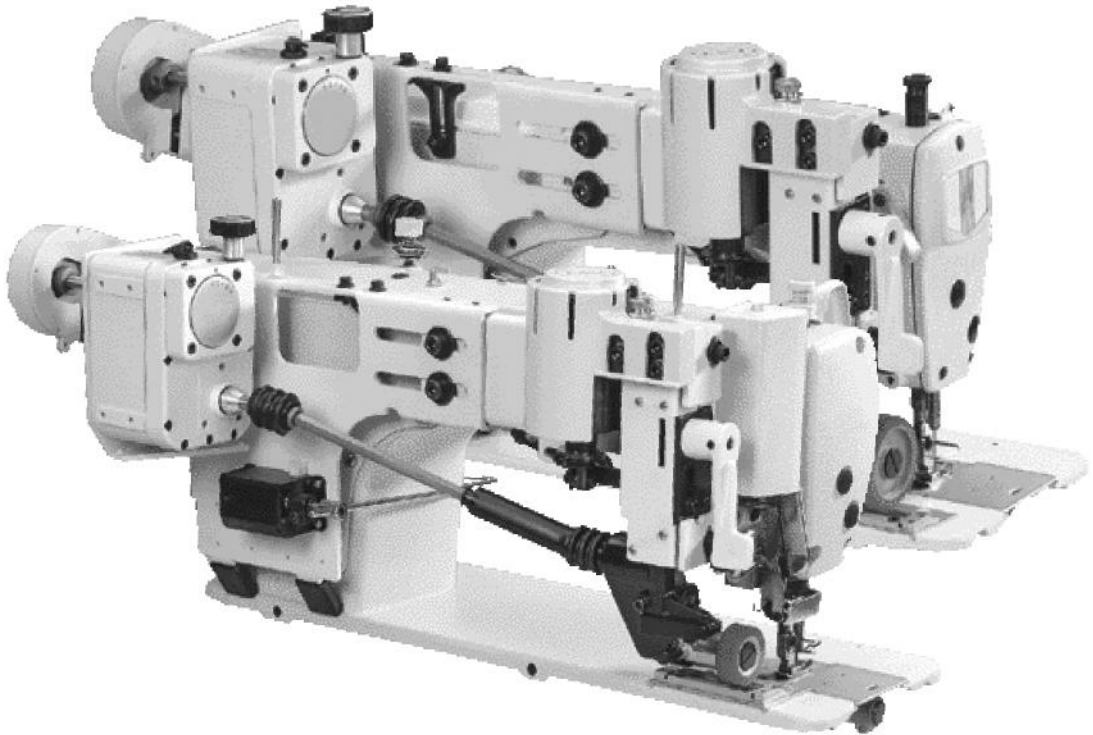

HPL 系列
SERIES

快速安裝指南

QUICK INSTALL GUIDE



安裝便捷 · 效果更好
您最佳的選擇

目錄

Contents

簡易組合圖.....1

Combination

接線圖.....4

Wiring diagram

零件圖.....6

Parts list

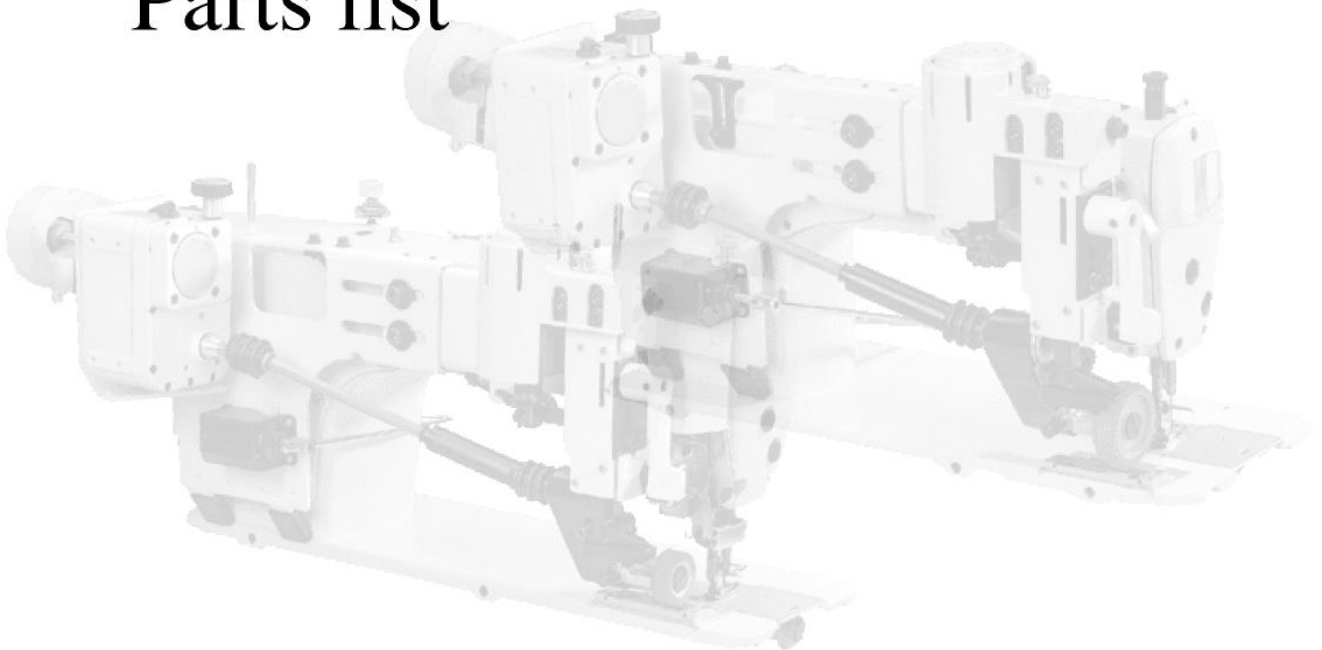

簡易組合圖 Combination



HPL系列可依不同廠牌零件互換
Parts fit most machine makes
of which the location may vary

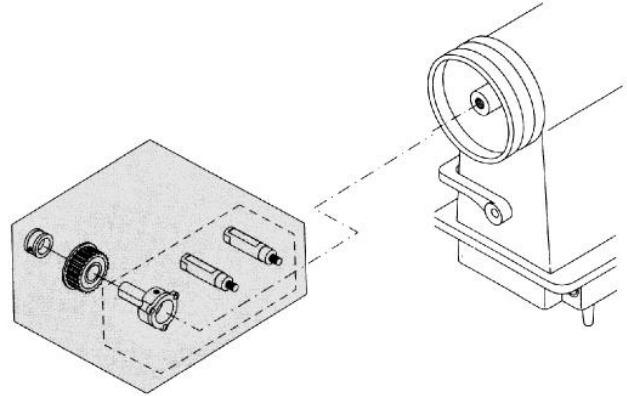

可依各廠牌位置的不同而做調整

In accordance to the different brand model to adjust the Puller more convenient.

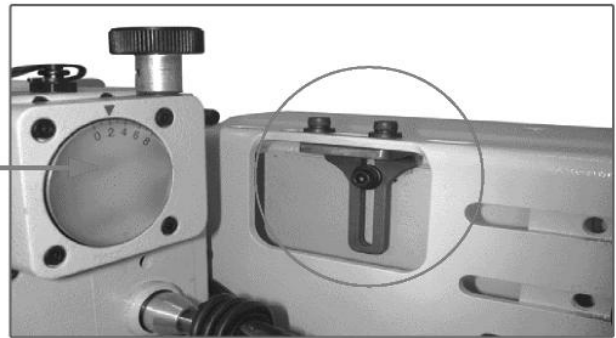
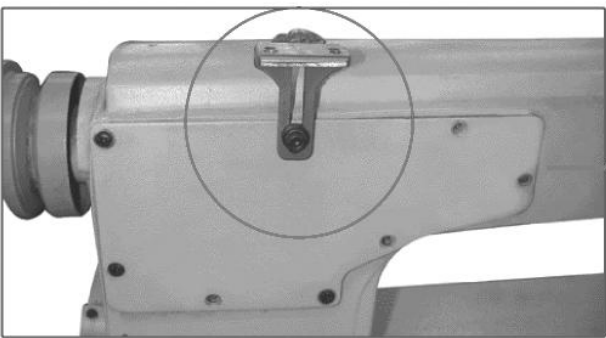
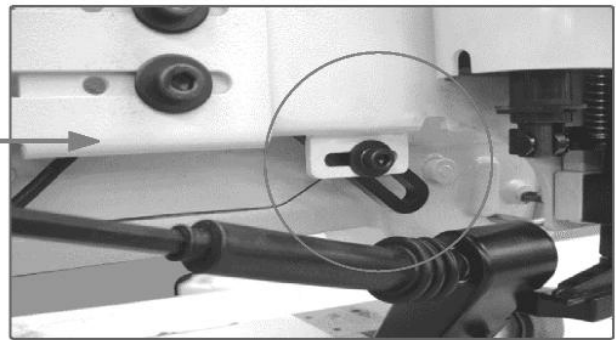
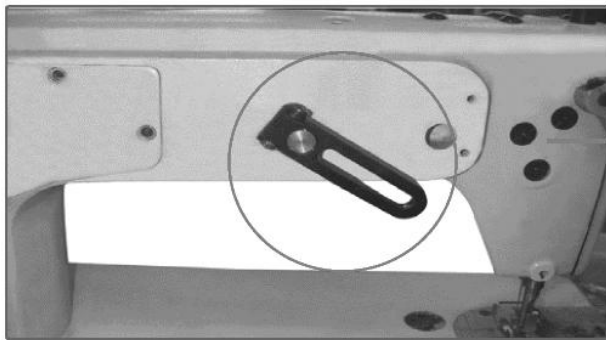

特有的飛輪底座具有滾輪，布料移動更加順暢

Individual flywheel foundation with roller bearings so that the cloth moves much more smoothly.

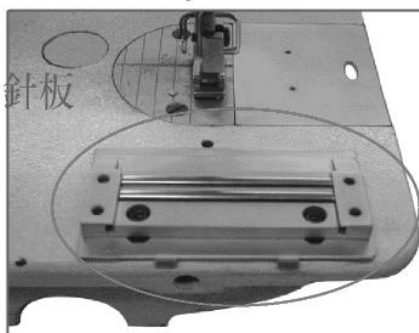

針板後之
飛輪底座
flywheel
foundation
after needle
board .

上下滑動
更加轉順
more smooth
with
upper and
underside
rolls.

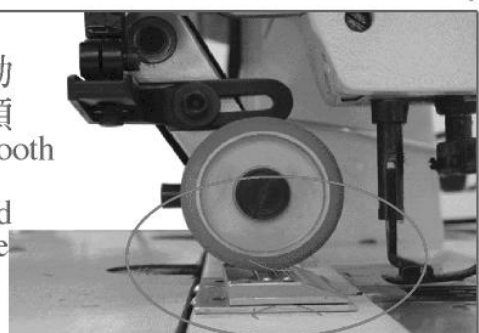



簡易組合圖 Combination

平行安裝之固定桿 (爲使安裝簡單，安裝固定後拆除)

Special gauge ensuring the puller is installed horizontally and as third hand while installing.

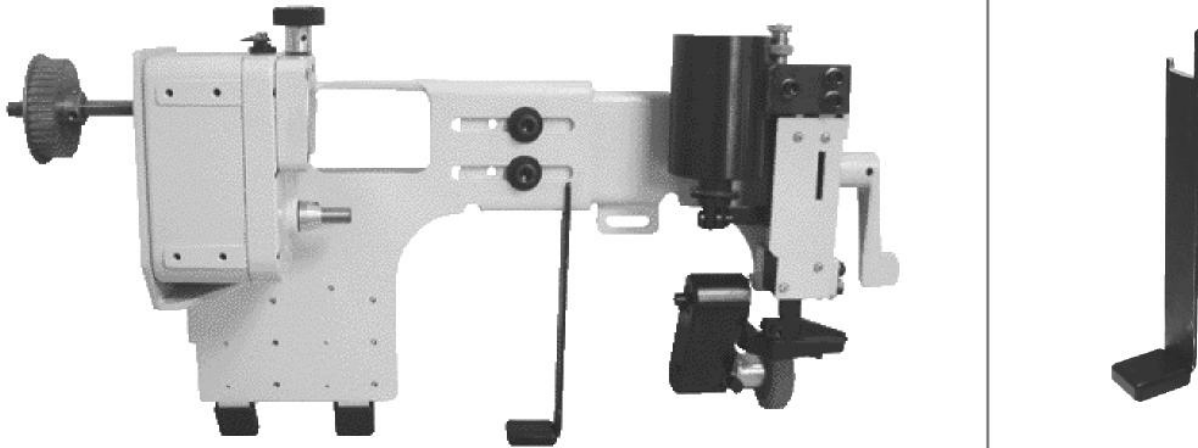

時規皮帶鬆緊固定螺絲，可依所需調整皮帶鬆緊

Timing belt tightening screw.

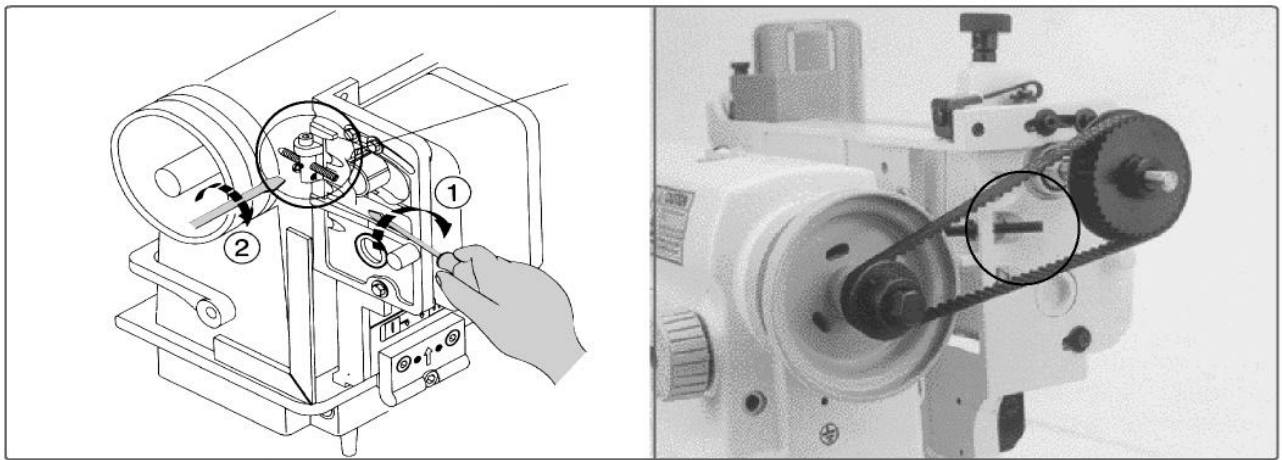

入力軸定位

Adjust input shaft position

一般針車定位時，
針車提升至最高點
General type, needle
to the toppest position

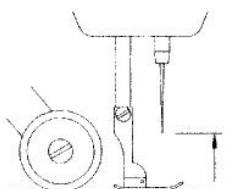

針送針車定位時，
針車下降至最低點
Needle feed type, needle
to the lowest position

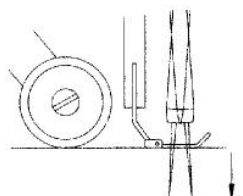

變速機的红線對齊入力軸紅線後，上緊時規齒輪螺絲
Meet the both red line on transmission input shaft,
tighten the timing gear screw

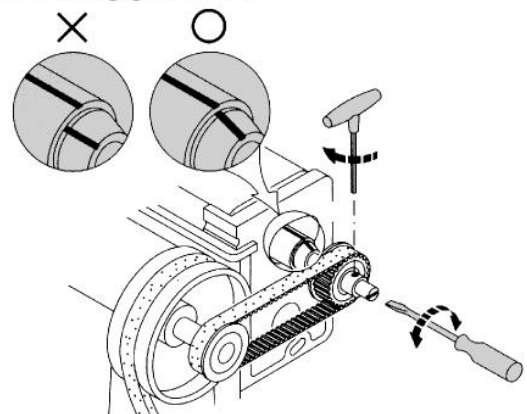

簡易組合圖 Combination



皮帶蓋安裝固定螺絲
Safety belt cover adjustment screws

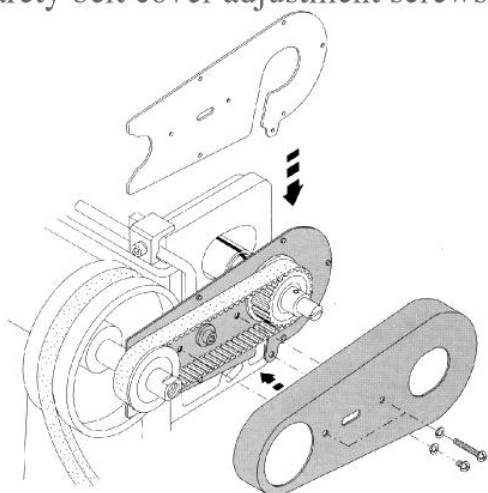

安全扣
Machine rest latch for maintenance

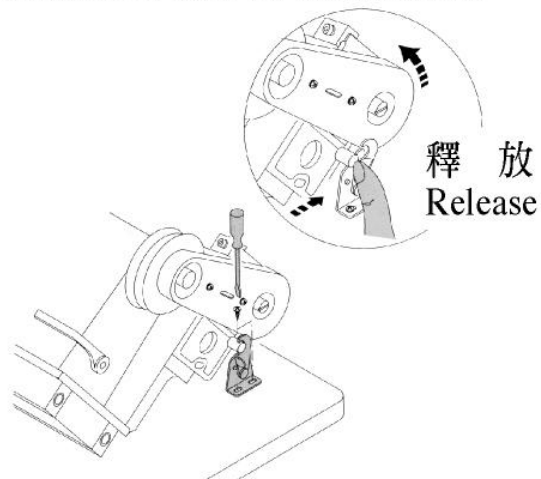

配合針車送料調整
Feeding adjustment

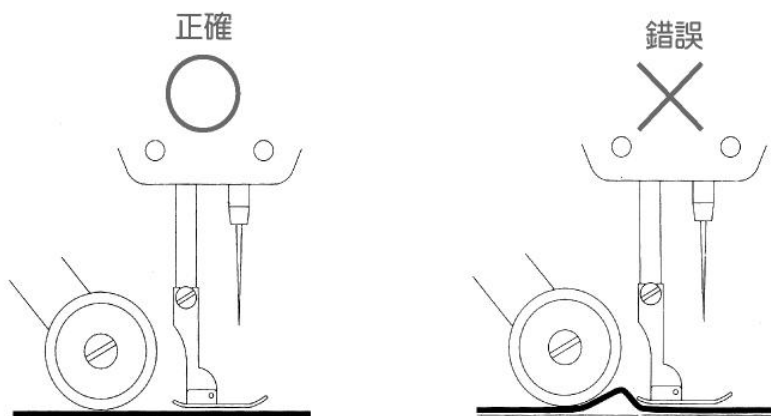
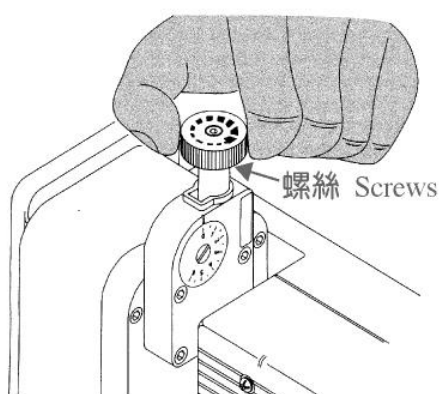

手動迴針
Manual reverse stitch

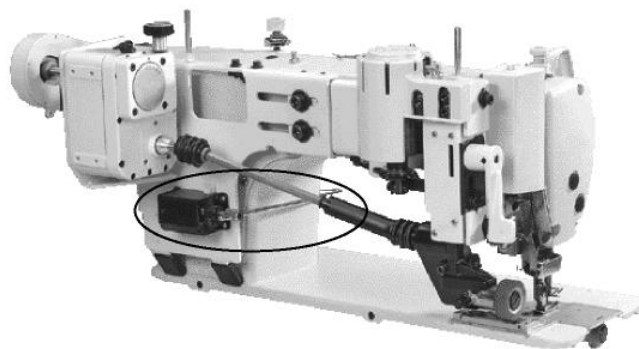
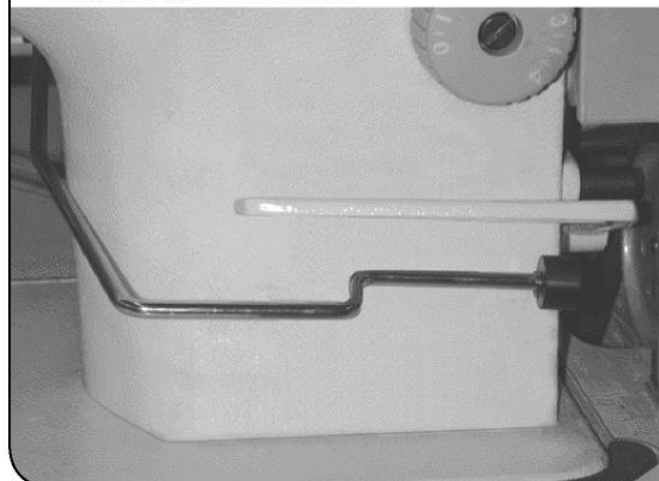



接線圖 Wiring diagram

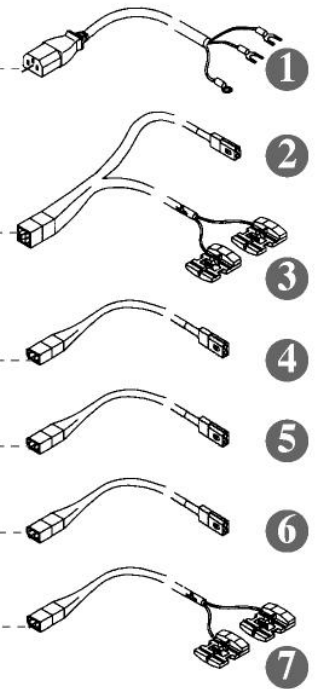
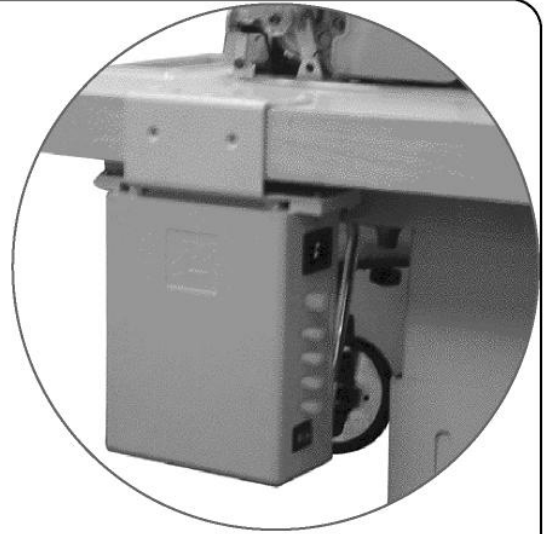
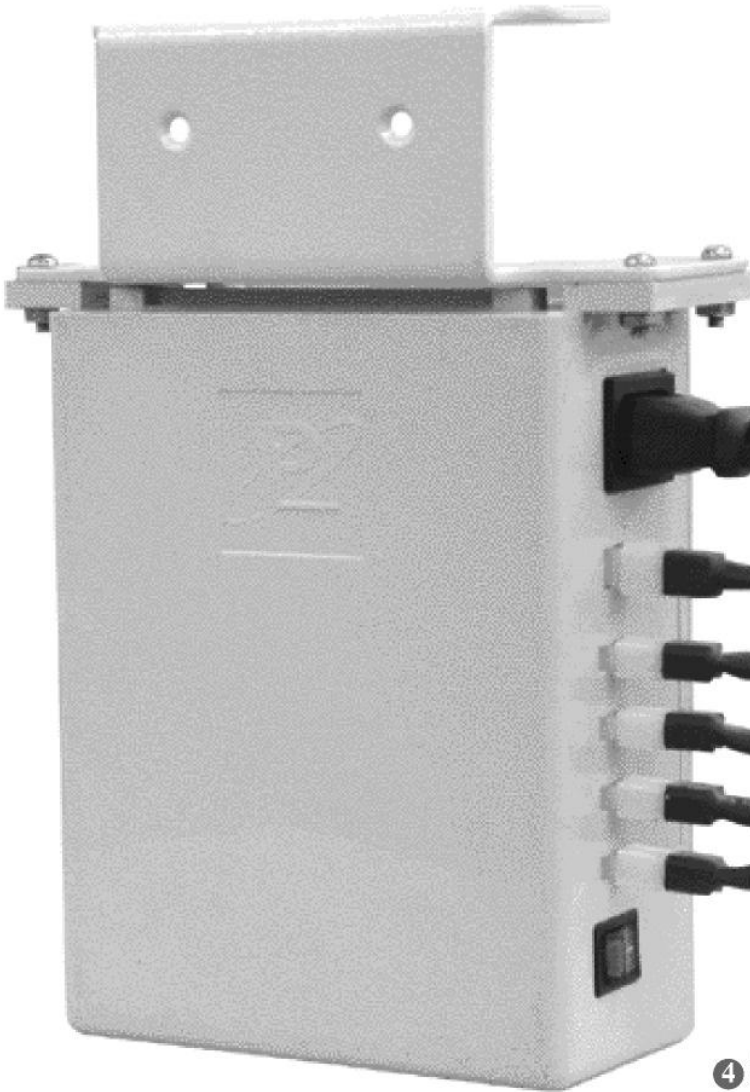

① 接電源
To Power supply outlet

② 接電磁鐵
To Solenoid outlet

③ 接DC24~48V自動倒針電磁電源線
To DC24~48V N.P. motor power
cords of auto-reverse.

④ 接迴針開關
To Reverse stitch switch

⑤ 接膝動式開關
To Knee lifter switch

⑥ 接腳動式懸掛開關
To Knee lifter suspensin switch

⑦ 接壓腳自動提升電磁鐵
To solenoid power cords of outo-lifter



接線圖 Wiring diagram

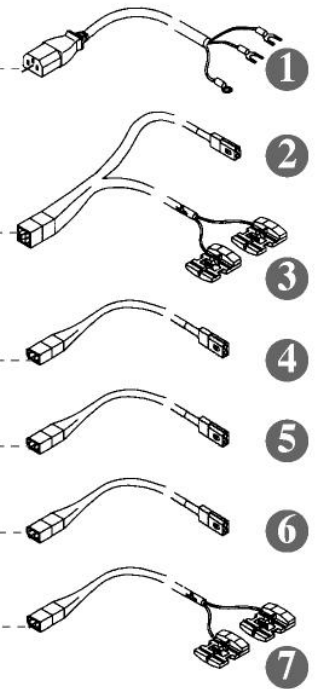
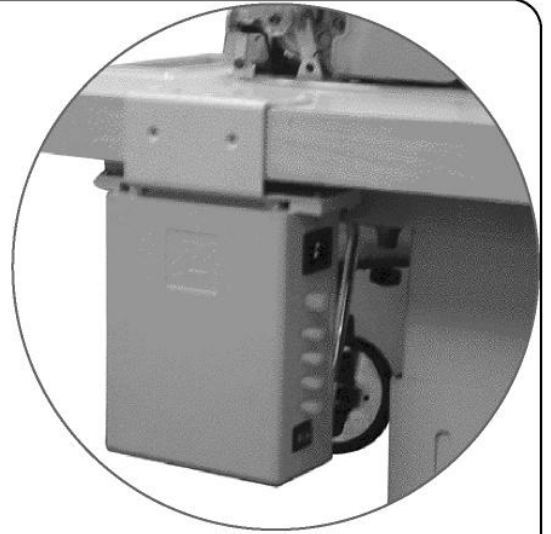
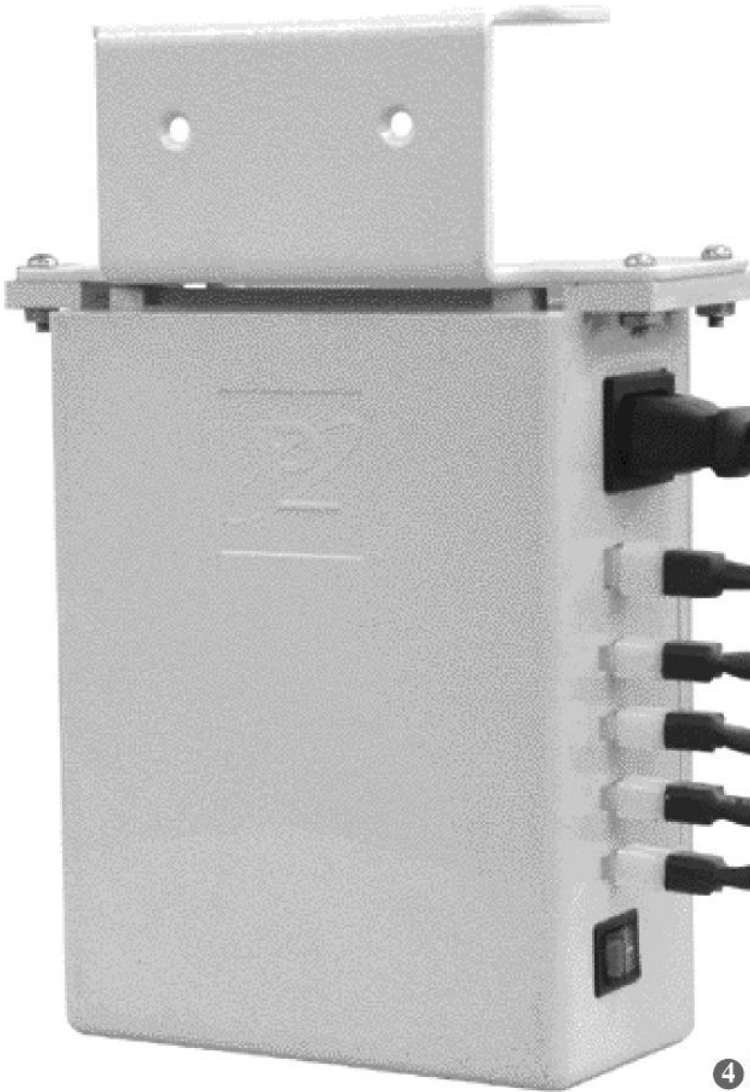

① 接電源
To Power supply outlet

② 接電磁鐵
To Solenoid outlet

③ 接DC24~48V自動倒針電磁電源線
To DC24~48V N.P. motor power
cords of auto-reverse.

④ 接迴針開關
To Reverse stitch switch

⑤ 接膝動式開關
To Knee lifter switch

⑥ 接腳動式懸掛開關
To Knee lifter suspensin switch

⑦ 接壓腳自動提升電磁鐵
To solenoid power cords of outo-lifter

接線圖 Wiring diagram



- 1** 電源線及地線 (電源: AC100V~220VC)
Power cords and earth terminal (AC100V~220VC power source)

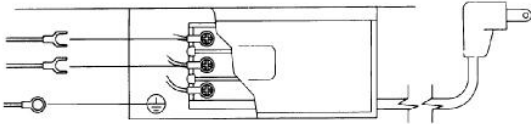

- 2** 電磁鐵
Solenoid

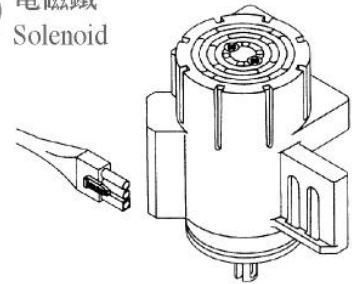

- 3** 接於自動切線針車倒針用電磁電源上 (DC24~48V)
Finding and connecting the power cords of auto-reverse solenoid (DC24~48V)

無自動切線之針車此線無需使用並將蓋子蓋上
For nonautomatic-trimming machine, keep this wire connector

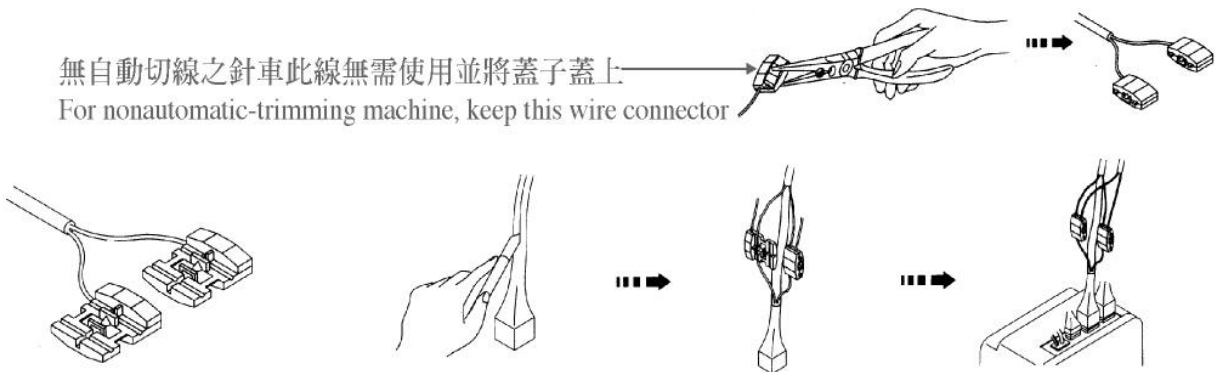

- 4** 迴針開關
Microswitch for reverse lever

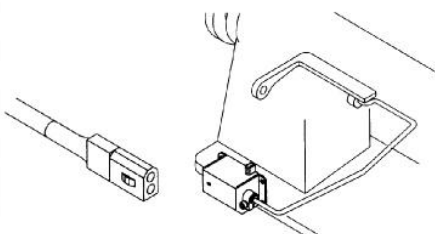

- 5** 膝動開關
Microswitch for knee presser fot lifter

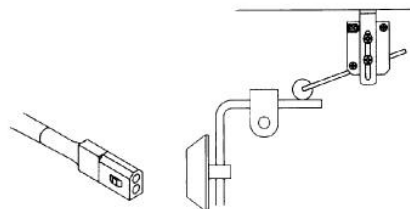

- 6** 懸吊式開關
Suspension microswitch

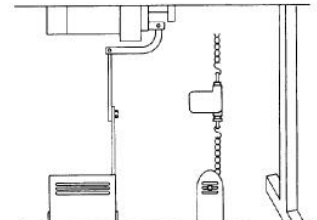

- 7** 接壓腳自動提升電磁鐵電源線
To solenoid power cords of auto-lifter

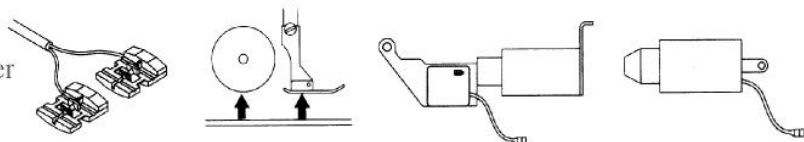



零件图 Parts list

