

# **HTFU-600 UPPER TAPE FEEDER (1-3LINES)**

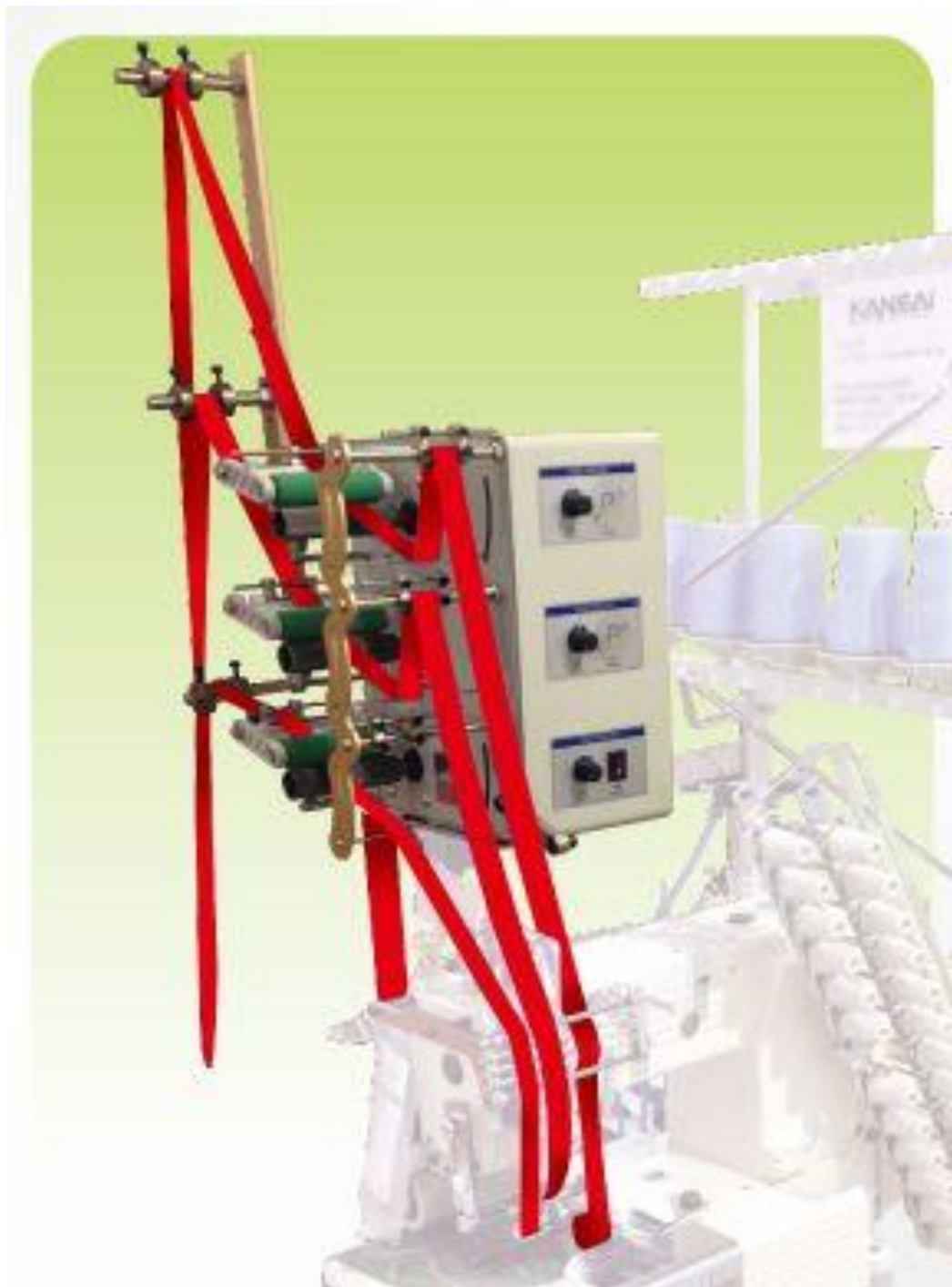

**HTFU-600 使用條帶注意**  
**UNCURLER OPERATION GUIDE**

**條帶使用圖**  
**UNCURLER OPERATION GUIDE**

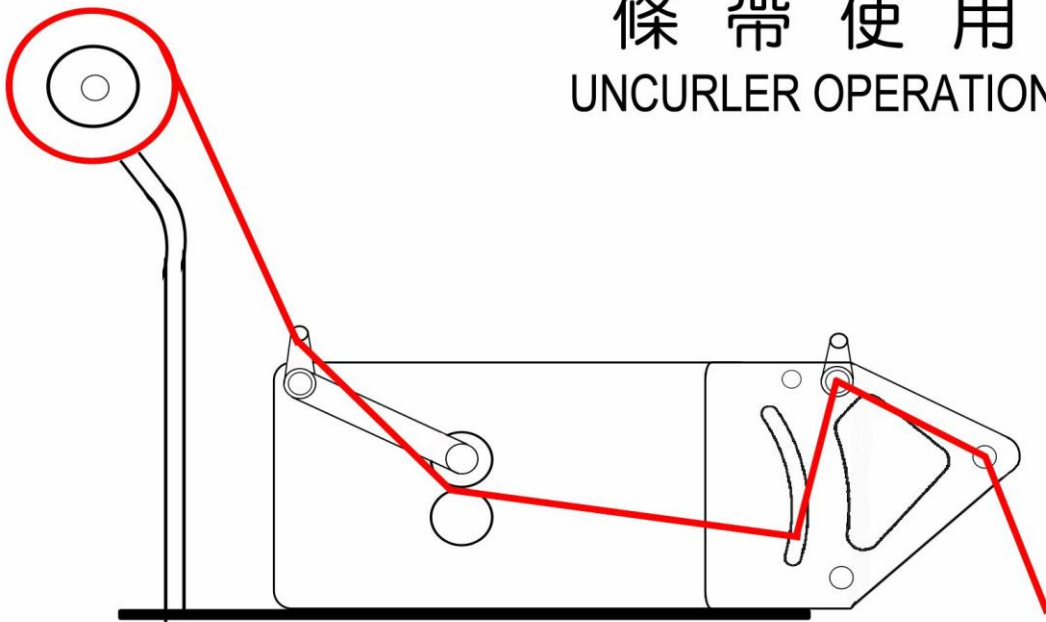

**電壓注意 VOLTAGE NOTICE**

**90V-240V**

# HTFU-600 旋鈕式

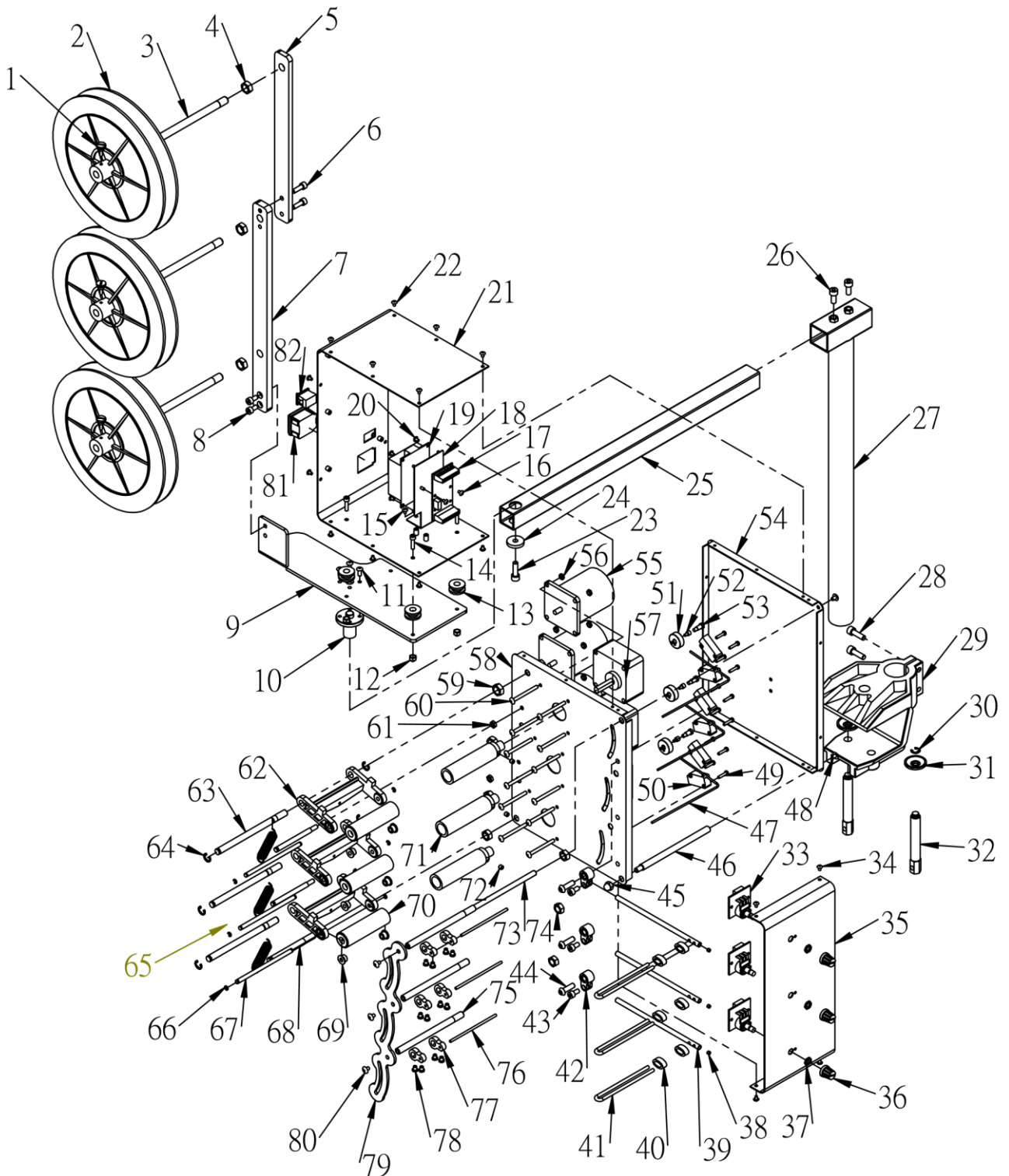

# **HTFU-600 UPPER TAPE FEEDER (1-3LINES)**

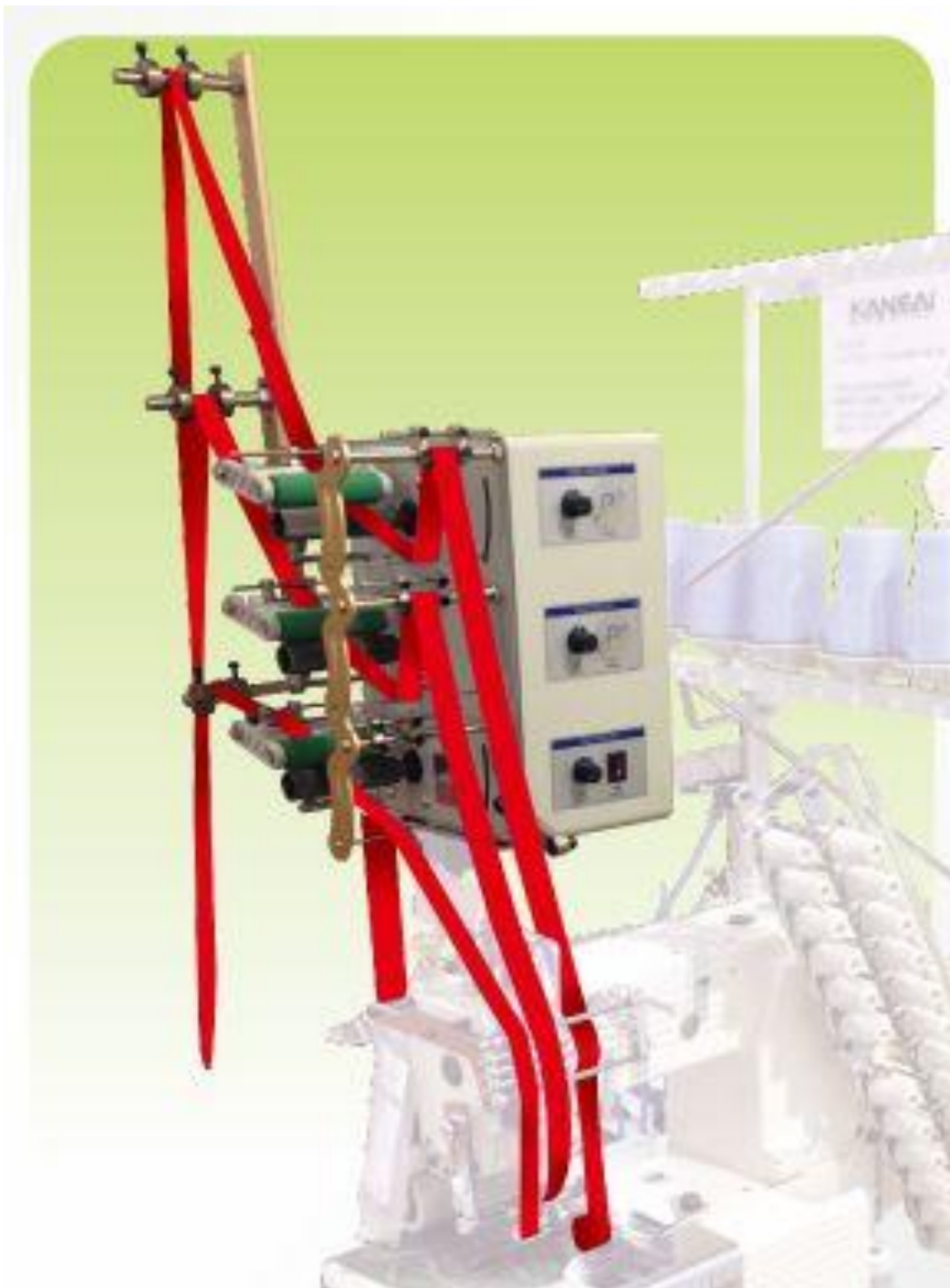

## HTFU-600 使用條帶注意

### UNCURLER OPERATION GUIDE

#### 條帶使用圖 UNCURLER OPERATION GUIDE

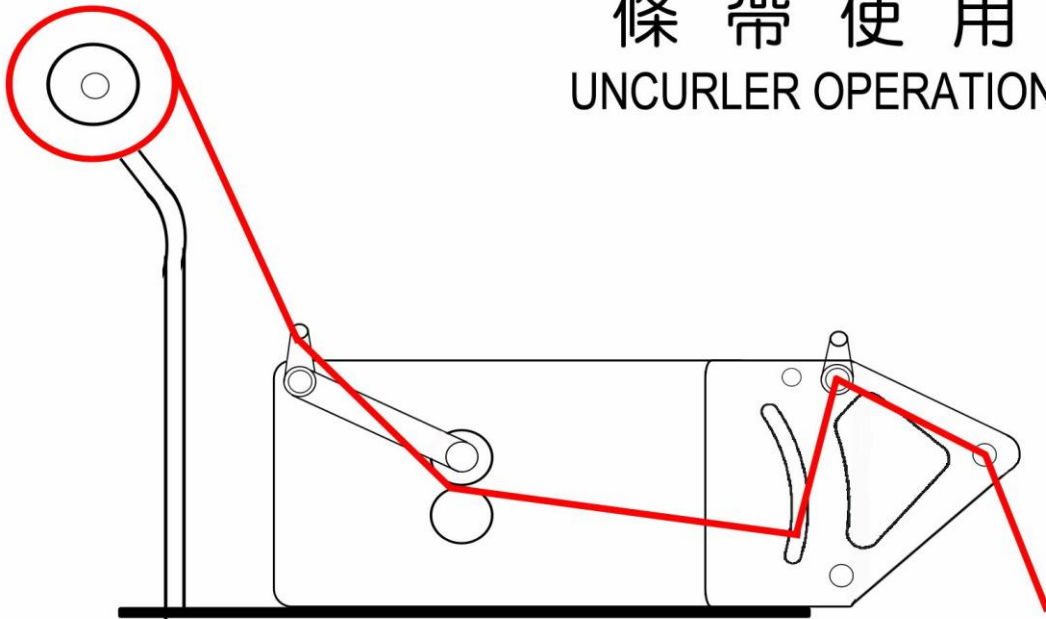

#### 電壓注意 VOLTAGE NOTICE

90V-240V

# HTFU-600 數位式

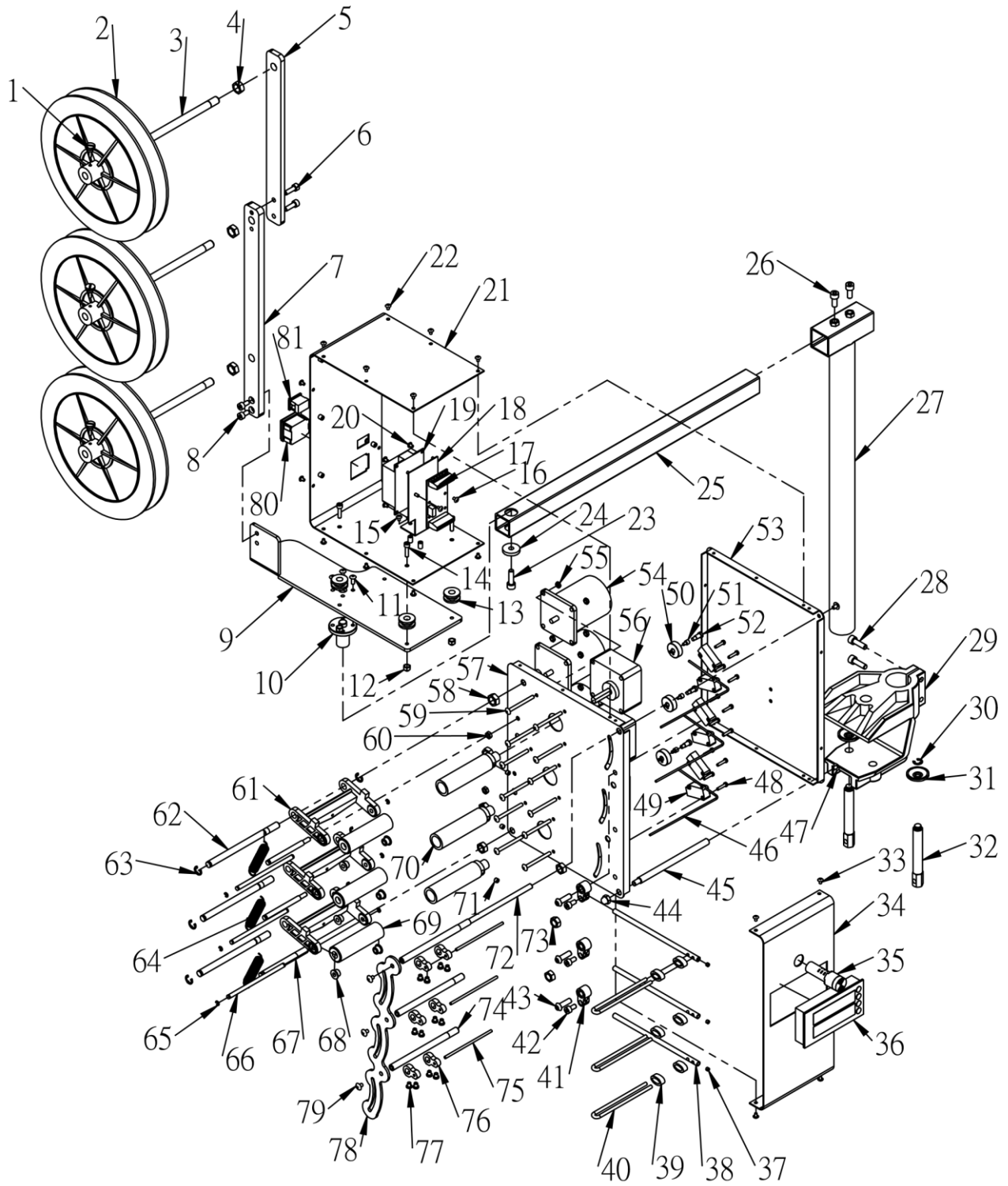

# HTFU-600P 面板操作說明書

## Upper Tape Feeder Device Panel Operation Instructions

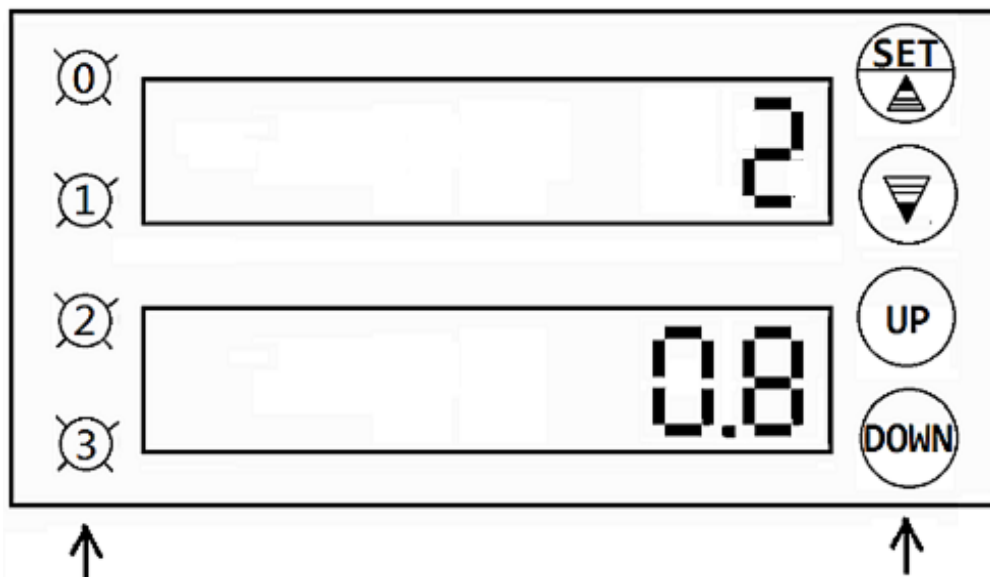

### A. 燈號指示 Lamp indication

指示燈 Lamp	狀態 State		
	常亮 On	熄滅 Off	閃爍 Crash
① 異常指示 Error			
② 上滾輪 Upper	開啓 ON	關閉 Off	異常Error
③ 中滾輪 Middle	開啓 ON	關閉 Off	異常Error
④ 下滾輪 Lower	開啓 ON	關閉 Off	異常Error

### B. 按鍵 Button

按鍵 Button	功能 Function
	① 開啓/關閉 On / Off
	② 開啓/關閉 On / Off
	③ 開啓/關閉 On / Off

### C. 更改送料時間

參數 Parameter	功能 Function
D200(上滾輪) Upper	送料時間(0.1S) Feeding time (0.1S)
D201(中滾輪) Middle	送料時間(0.1S) Feeding time (0.1S)
D202(下滾輪) Lower	送料時間(0.1S) Feeding time (0.1S)
D203	異常停機時間(0.1S) Abnormal downtime (0.1S)



## 參數設定(第 1~4 項)&開啓/關閉(第 5~8 項)



Parameter setting (items 1~4) & on/off (items 5~8)



送料時間設定 Feed time setting



1、押著  鍵 3 秒鐘以上進入參數設定。

Press the  for more than 3 seconds to enter the parameter setting.

2、利用  或  鍵，選擇欲修改之參數 (D200(上滾輪)、D201(中滾輪)、D202(下滾輪)、D203.....)





Use the  or  to select the parameter to be modified (D200 (upper), D201 (middle), D202 (lower), D203.....)





3、利用  或  鍵，增加/減少參數之數值。

Use  or  to increase/decrease the value of the parameter

4、押著  鍵 3 秒鐘以上退出參數設定。





Press the  for more than 3 seconds to exit the parameter setting.





5、押  鍵 2 秒以上滾輪"開啓" ( 常亮)、再押  鍵 2 秒以上滾輪"關閉" ( 熄滅)。

Press the  for 2 seconds to turn the wheel "on" ( on), and then press the  for 2 seconds to turn the upper wheel "off" ( off).

依序循環,同時顯示 D200(上滾輪\_停止送料時間(S))。





Cycle in sequence, and display D200 at the same time (upper wheel\_stop feeding time (S)).





6、押  鍵 2 秒以中滾輪"開啓" ( 常亮)、再押  鍵 2 秒以中滾輪"關閉" ( 熄滅)。

Press the  for 2 seconds to turn the middle wheel "on" ( on), and then press the  for 2 seconds to turn the middle wheel "off" ( off).

依序循環,同時顯示 D201(中滾輪\_停止送料時間(S))



Cycle in sequence, and display D201 at the same time (middle wheel\_stop feeding time (S)).



7、押  鍵 2 秒以下滾輪"開啓" ( 常亮)、再押  鍵 2 秒以下滾輪"關閉" ( 熄滅)。

Press the  for 2 seconds to turn the lower wheel "on" ( on), and then press the  for 2 seconds to turn the lower wheel "off" ( off).

依序循環,同時顯示 D202(下滾輪\_停止送料時間(S))

Cycle in sequence, and display D202 at the same time (lower wheel\_stop feeding time (S)).

8、異常時,  閃爍, 外部異常燈與蜂鳴器同時動作(可輕押一次  鍵關閉蜂鳴器)。

When abnormal,  flashes, and the external abnormal lamp operates simultaneously with the buzzer (you can press the  once to turn off the buzzer).

滾輪設定 Wheel setting



# **HTFU-600 UPPER TAPE FEEDER (1-3LINES)**

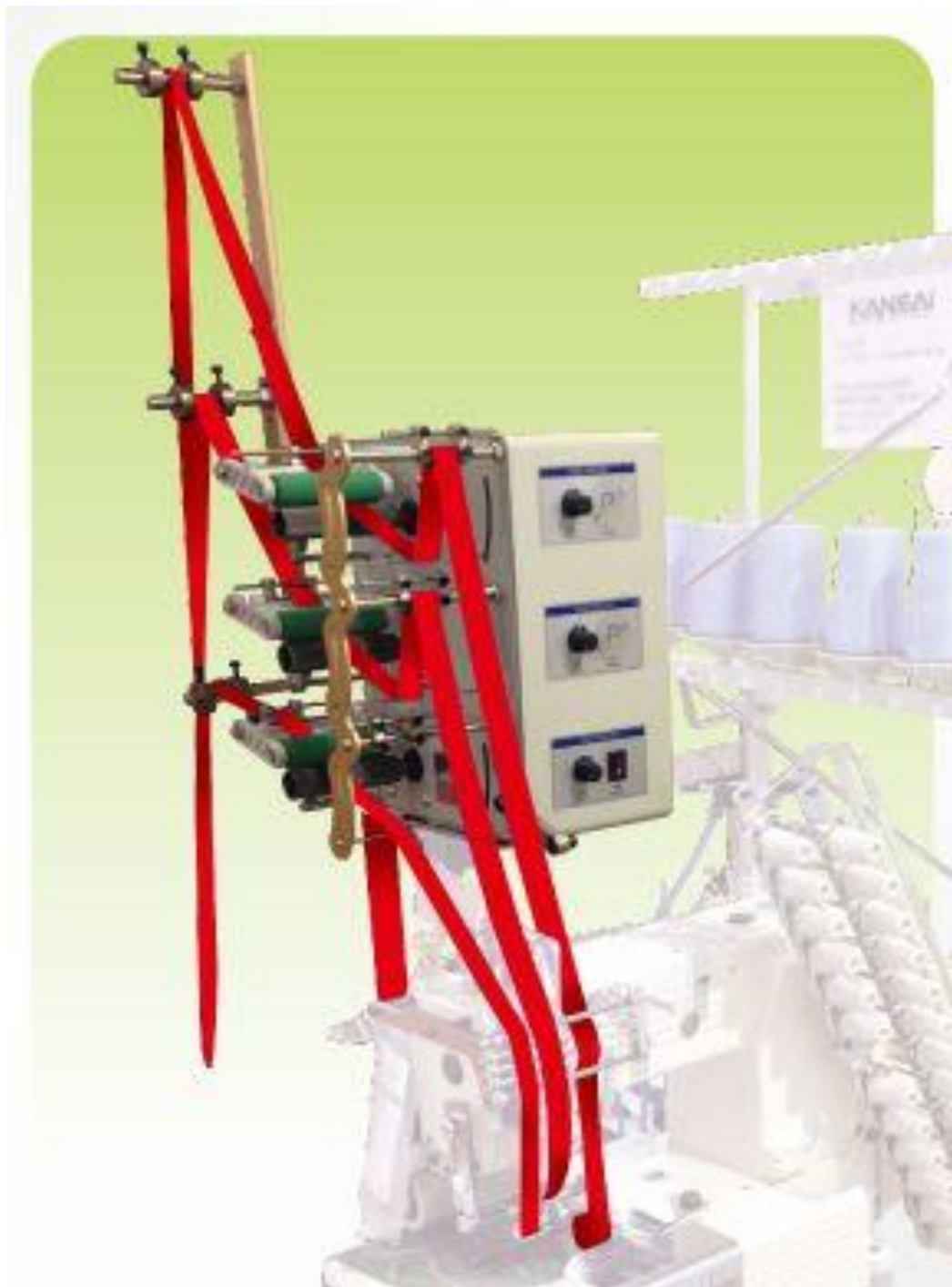

HTFU-600 使用條帶注意  
UNCURLER OPERATION GUIDE

條帶使用圖  
UNCURLER OPERATION GUIDE

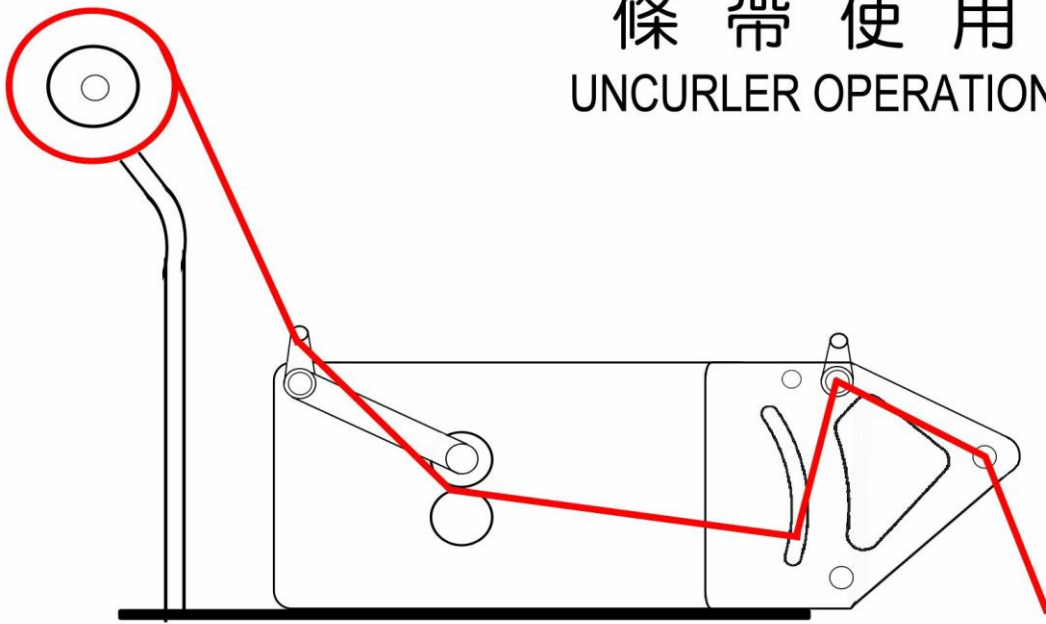

電壓注意 VOLTAGE NOTICE

90V-240V

# HTFU-600(電路板)

